

BAĞLANTI NOKTANIZ

FİYAT LİSTESİ
AĞUSTOS / 2025

STANDART TRİFONLU KELEPÇE

ÜRÜN KODU	SIKMA ARALIĞI	ÖLÇÜ	L (mm)	H (mm)	M	S (mm)	B (mm)	T	KOLİ ADETİ	FİYAT
CXST 1/2	21 - 26	1/2"	62,5	88	M5	1	20	Ø7x70	150	17,35 ₺
CXST 3/4	26 - 30	3/4"	68,5	91	M5	1	20	Ø7x70	125	19,05 ₺
CXST 1	33 - 37	1"	76	94,5	M5	1	20	Ø7x70	100	20,45 ₺
CXST 11/4	40 - 46	11/4"	91,5	99	M5	1,2	20	Ø7x70	75	25,50 ₺
CXST 11/2	48 - 53	11/2"	99	102,5	M5	1,2	20	Ø7x70	50	27,55 ₺
CXST 2	60 - 66	2"	112	109	M5	1,2	20	Ø7x70	50	31,1 ₺
CXST 21/2	75 - 84	21/2"	134	118	M6	1,5	25	Ø7x70	25	50,53 ₺
CXST 3	87 - 96	3"	145	123,5	M6	1,5	25	Ø7x70	20	57 ₺
CXST 4	109 - 119	4"	170	136	M6	1,5	25	Ø7x70	15	69,50 ₺
CXST 41/2	122 - 135	41/2"	184	142,5	M6	1,5	25	Ø7x70	15	101,40 ₺
CXST 5	135 - 148	5"	197	148	M6	2	25	Ø7x70	10	125 ₺
CXST 6	158 - 170	6"	222	154	M6	2	25	Ø7x70	10	148,50 ₺

Lastikli sıkma ölçüsü / Clamping range with rubber



Lastiksiz sıkma ölçüsü / Clamping range without rubber

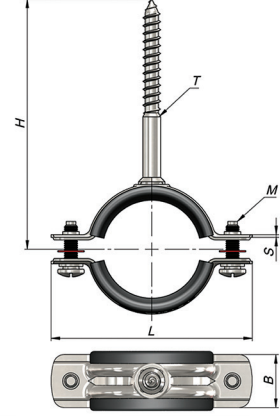

UZUN STANDART TRİFONLU KELEPÇE

ÜRÜN KODU	SIKMA ARALIĞI	ÖLÇÜ	L (mm)	H (mm)	M	S (mm)	B (mm)	T	KOLİ ADETİ	FİYAT
CXUT 1/2	21 - 26	1/2"	62,5	118	M5	1	20	Ø7x100	150	19,85 ₺
CXUT 3/4	26 - 30	3/4"	68,5	121	M5	1	20	Ø7x100	100	21,20 ₺
CXUT 1	33 - 37	1"	76	124,5	M5	1	20	Ø7x100	75	23,05 ₺
CXUT 11/4	40 - 46	11/4"	91,5	129	M5	1,2	20	Ø7x100	50	28,25 ₺
CXUT 11/2	48 - 53	11/2"	99	132,5	M5	1,2	20	Ø7x100	50	30,15 ₺
CXUT 2	60 - 66	2"	112	139	M5	1,2	20	Ø7x100	40	34,50 ₺
CXUT 21/2	75 - 84	21/2"	134	148	M6	1,5	25	Ø7x100	20	53,55 ₺
CXUT 3	87 - 96	3"	145	153,5	M6	1,5	25	Ø7x100	20	66,60 ₺
CXUT 4	109 - 119	4"	170	166	M6	1,5	25	Ø7x100	15	79,30 ₺
CXUT 41/2	122 - 135	41/2"	184	172,5	M6	1,5	25	Ø7x100	15	105,50 ₺
CXUT 5	135 - 148	5"	197	178	M6	2	25	Ø7x100	10	131,50 ₺
CXUT 6	158 - 170	6"	222	184	M6	2	25	Ø7x100	10	159,90 ₺

Lastikli sıkma ölçüsü / Clamping range with rubber



Lastiksiz sıkma ölçüsü / Clamping range without rubber

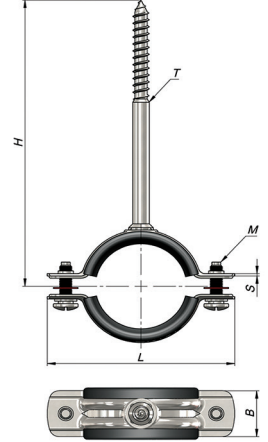

SPRİNKLER KELEPÇE

ÜRÜN KODU	ÖLÇÜ	Ø D (mm)	L (mm)	H (mm)	-	S (mm)	B (mm)	Ø d (mm)	KOLİ ADETİ	FİYAT
CXSP 1/2	1/2"	28	51,5	36,5	-	1	25	10,5	150	12,15 ₺
CXSP 3/4	3/4"	30	53,5	37,5	-	1	25	10,5	125	12,90 ₺
CXSP 1	1"	36	65,5	46,5	-	1	25	10,5	100	13,45 ₺
CXSP 11/4	11/4"	46	79,9	55,7	-	1,2	25	10,5	75	18,55 ₺
CXSP 11/2	11/2"	52	85,9	58,7	-	1,2	25	10,5	60	19,10 ₺
CXSP 2	2"	66	99,9	65,7	-	1,2	25	10,5	50	22,01 ₺
CXSP 21/2	21/2"	78	116	75,5	-	1,5	25	10,5	35	33,58 ₺
CXSP 3	3"	92	132	84,5	-	1,5	25	10,5	25	38,30 ₺
CXSP 4	4"	116	167,5	107,5	-	2	25	10,5	30	57,90 ₺
CXSP 5	5"	142	200	126,5	-	2,5	25	13	30	81,05 ₺
CXSP 6	6"	170	238	150,5	-	2,5	25	13	30	94,05 ₺
CXSP 8	8"	222	311,5	197,5	-	3	30	17	10	221 ₺

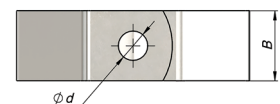
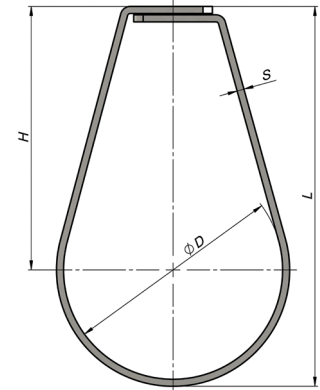

FİYAT LİSTESİ

TL / ADET



Lastikli sıkma ölçüsü / Clamping range with rubber



Lastiksiz sıkma ölçüsü / Clamping range without rubber

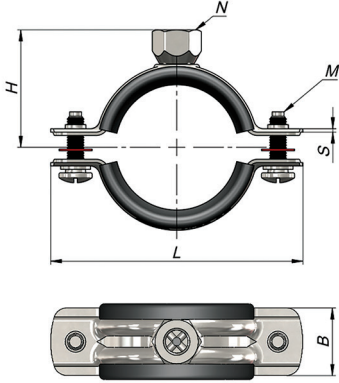

SOMUNLU KELEPÇE

ÜRÜN KODU	SIKMA ARALIĞI	ÖLÇÜ	L (mm)	H (mm)	M	S (mm)	B (mm)	N	KOLİ ADETİ	FİYAT
CXS 1/2	21 - 26	1/2"	62,5	28	M5	1	20	M8	200	15,55 ₺
CXS 3/4	26 - 30	3/4"	68,5	31	M5	1	20	M8	150	16,97 ₺
CXS 1	33 - 37	1"	76	34,5	M5	1	20	M8	150	19,05 ₺
CXS 11/4	40 - 46	11/4"	91,5	39	M5	1,2	20	M8	100	23,10 ₺
CXS 11/2	48 - 53	11/2"	99	42,5	M5	1,2	20	M8	75	25,25 ₺
CXS 2	60 - 66	2"	112	49	M5	1,2	20	M8	50	28,80 ₺
CXS 21/2	75 - 84	21/2"	134	60	M6	1,5	25	M10	40	49,55 ₺
CXS 3	87 - 96	3"	145	65,5	M6	1,5	25	M10	40	55 ₺
CXS 4	109 - 119	4"	170	78	M6	1,5	25	M10	30	65,10 ₺
CXS 41/2	122 - 135	41/2"	184	84,5	M6	1,5	25	M10	30	76,10 ₺
CXS 5	135 - 148	5"	197	91	M6	2	25	M10	25	93,10 ₺
CXS 6	158 - 170	6"	222	103,5	M6	2	25	M10	20	108,10 ₺

Lastikli sıkma ölçüsü / Clamping range with rubber



Lastiksiz sıkma ölçüsü / Clamping range without rubber

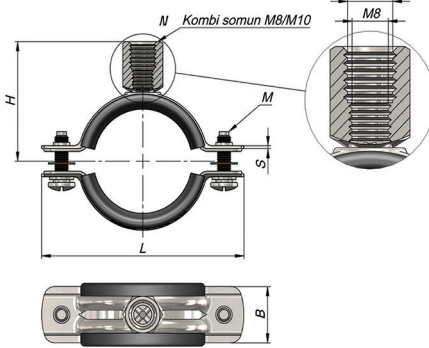

KOMBİ SOMUNLU KELEPÇE

ÜRÜN KODU	SIKMA ARALIĞI	ÖLÇÜ	L (mm)	H (mm)	M	S (mm)	B (mm)	N	KOLİ ADETİ	FİYAT
CXKS 1/2	21 - 26	1/2"	62,5	36	M5	1	20	M8/10	200	20,10 ₺
CXKS 3/4	26 - 30	3/4"	68,5	39	M5	1	20	M8/10	150	21,70 ₺
CXKS 1	33 - 37	1"	76	42,5	M5	1	20	M8/10	150	23,50 ₺
CXKS 11/4	40 - 46	11/4"	91,5	47	M5	1,2	20	M8/10	100	28,05 ₺
CXKS 11/2	48 - 53	11/2"	99	50,5	M5	1,2	20	M8/10	75	30,10 ₺
CXKS 2	60 - 66	2"	112	57	M5	1,2	20	M8/10	50	33,65 ₺
CXKS 21/2	75 - 84	21/2"	134	66	M6	1,5	25	M8/10	40	52,60 ₺
CXKS 3	87 - 96	3"	145	71,5	M6	1,5	25	M8/10	40	58,40 ₺
CXKS 4	109 - 119	4"	170	84	M6	1,5	25	M8/10	30	69,30 ₺
CXKS 41/2	122 - 135	41/2"	184	90,5	M6	1,5	25	M8/10	30	80,50 ₺
CXKS 5	135 - 148	5"	197	97	M6	2	25	M8/10	25	97,80 ₺
CXKS 6	158 - 170	6"	222	109,5	M6	2	25	M8/10	20	113,30 ₺

AĞIR YÜK KAFALI KELEPÇE

ÜRÜN KODU	SIKMA ARALIĞI	ÖLÇÜ	L (mm)	H (mm)	M	SxB (mm)	ExF (mm)	K	KOLİ ADETİ	FİYAT
CXAY 1/2	21 - 28	1/2"	81	41	M8	2x25	10,5x14	2x25x40	50	53,95 ₺
CXAY 3/4	25 - 32	3/4"	87	42,5	M8	2x25	10,5x14	2x25x40	50	56,80 ₺
CXAY 1	33 - 40	1"	94	49,5	M8	2x25	10,5x14	2x25x40	50	60,85 ₺
CXAY 11/4	41 - 48	11/4"	103	55	M8	2x25	10,5x14	2x25x40	40	65,60 ₺
CXAY 11/2	48 - 56	11/2"	111	59	M8	2x25	10,5x14	2x25x40	40	70,90 ₺
CXAY 2	60 - 69	2"	125	66	M8	2x25	10,5x14	2x25x40	30	76,15 ₺
CXAY 21/2	75 - 81	21/2"	141	74	M8	2x25	10,5x14	2x25x40	25	84,40 ₺
CXAY 3	87 - 95	3"	154	80	M8	2x25	10,5x14	2x25x40	30	89,60 ₺
CXAY 4	109 - 119	4"	178	93	M8	2,5x30	12x14	2,5x30x40	25	132,05 ₺
CXAY 41/2	122 - 138	41/2"	192	101	M10	3x30	12x14	3x30x40	20	165,50 ₺
CXAY 5	136 - 147	5"	204	107	M10	3x30	12x14	3x30x40	15	205,40 ₺
CXAY 6	164 - 174	6"	229	120	M10	3x30	12x14	3x30x40	15	224,05 ₺

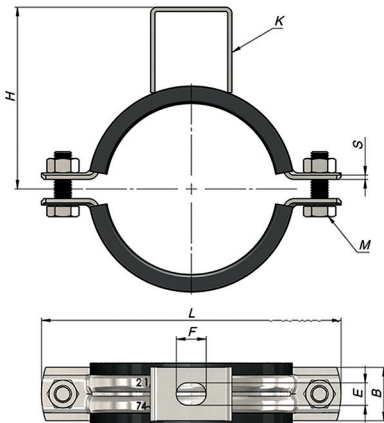



+90 545 126 85 37



+90 530 283 88 42



info@clampix.com.tr



esratesisat@hotmail.com



www.clampix.com.tr

Fabrika



Efer 4 Sanayi Sitesi Seyhan / ADANA

Ofis



Dağlıođlu Mahallesi 14088 Sokak No 8/A Seyhan / ADANA